

Krantz Components

Microdrall MD-....

Air distribution systems

Krantz

Microdrall

Construction design and mode of operation

Construction design

The main component of the Microdrall is the air outlet element **1** with square face. The air outlet element is available with square or circular slot array (see Figure 2).

The supply air is fed to the connection box **2** through the spigot **3**. The spigot is available with or without lip seal **7** and with or without volume flow damper **4**. The volume flow damper is adjustable from the room.

From the connection box the supply air is discharged into the room through the air outlet element **1** with numerous radial slots.

The air outlet element is easy to take down after removing the central fastening screw **5**. The complete air outlet unit is suspended at fixing points **6** at the connection box.

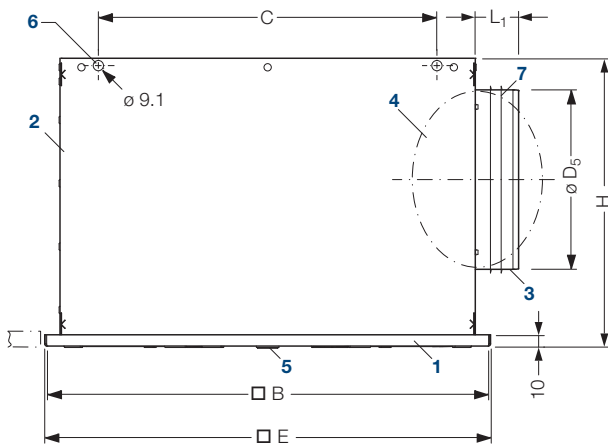

Fig. 1: Dimensions

Table 1: Technical data and dimensions

Size		600	625
Volume flow rate	l/s [m ³ /h]		
– square slot array	\dot{V}_{max}	208 [750]	
	$\dot{V}_{min}^{1+2)}$	61 [220]	
– circular slot array	\dot{V}_{max}	180 [650]	
	$\dot{V}_{min}^{1+2)}$	92 [330]	
Discharge height	m	2.7 – 4.5	
Dimensions			
B	mm	588	
C	mm	420	
$\varnothing D_5$	mm	249	
E	mm	595	620
H	mm	345	
L ₁	mm	60	
Weight W			
– Air outlet element	kg	2.7	
– Connection box	kg	8.5	
Max. temperature difference supply air–indoor air		–12 K when cooling +10 K when heating (≤ 3 m) + 5 K when heating (> 3 m)	

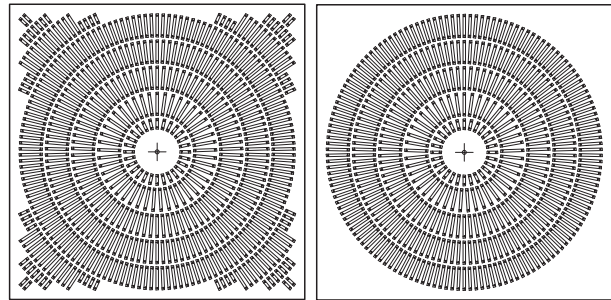

Fig. 2: Square face
left: square slot array
right: circular slot array

Mode of operation

The Microdrall generates turbulent mixing ventilation with high-induction radial air jets. The discharge direction is horizontal.

With air outlet installation **flush with ceiling** (Figure 3) and horizontal discharge direction, the high-turbulence air jets glide along the ceiling. The resulting flow mixes intensively with indoor air, with rapid temperature equalization as a result.

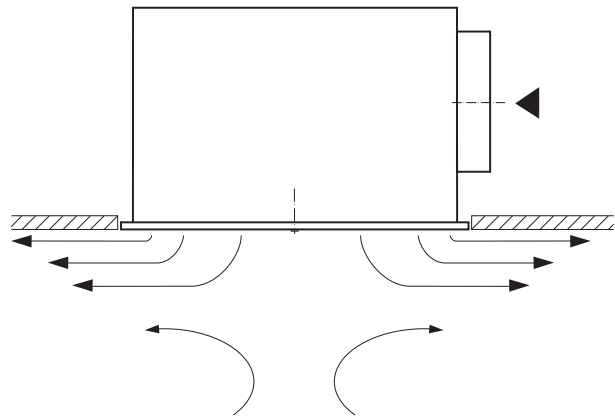

Fig. 3: Jet pattern with air outlet installed flush with ceiling

1) \dot{V}_{min} for installation flush with ceiling

2) \dot{V}_{min} for free suspension on request

Microdrall

Comfort criteria

Comfort criteria 1)

The outlet layout must comply with the maximum allowable indoor air velocities u in the occupied zone in cooling mode. The indoor air velocity depends on the cooling load that is to be removed from the room. The maximum specific cooling capacity \dot{q} depends on the discharge height and the maximum allowable indoor air velocity u (Graph 1).

Graph 1 enables to determine for the cooling mode the maximum specific volume flow rate $\dot{V}_{Sp\ max}$ in relation to the maximum specific cooling capacity and the maximum temperature difference $\Delta\vartheta_{max}$. The volume flow rate supplied to the room $\dot{V}_{Sp\ act}$ may not exceed this value.

Graph 2 enables to determine the minimum centre spacing between two outlets on the basis of the maximum specific volume flow rate.

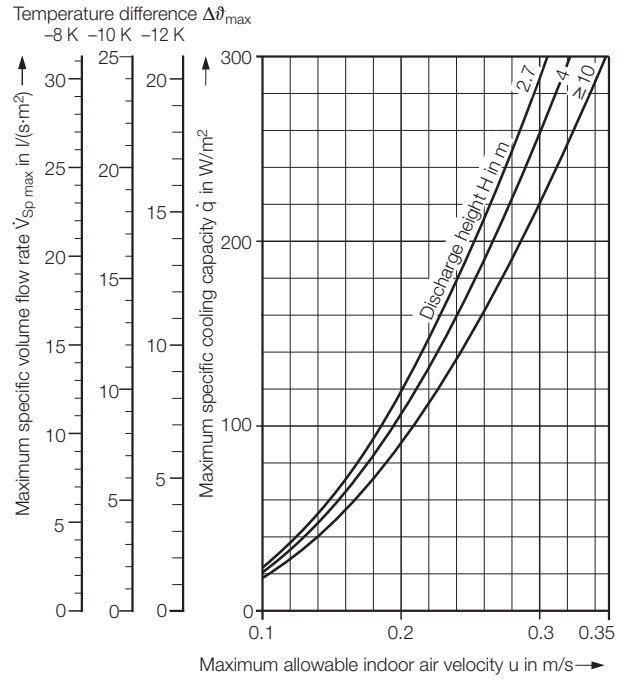

Graph 1: Maximum specific volume flow rate

1) See our brochure ref. TB 69 'Layout specifications for thermal comfort'

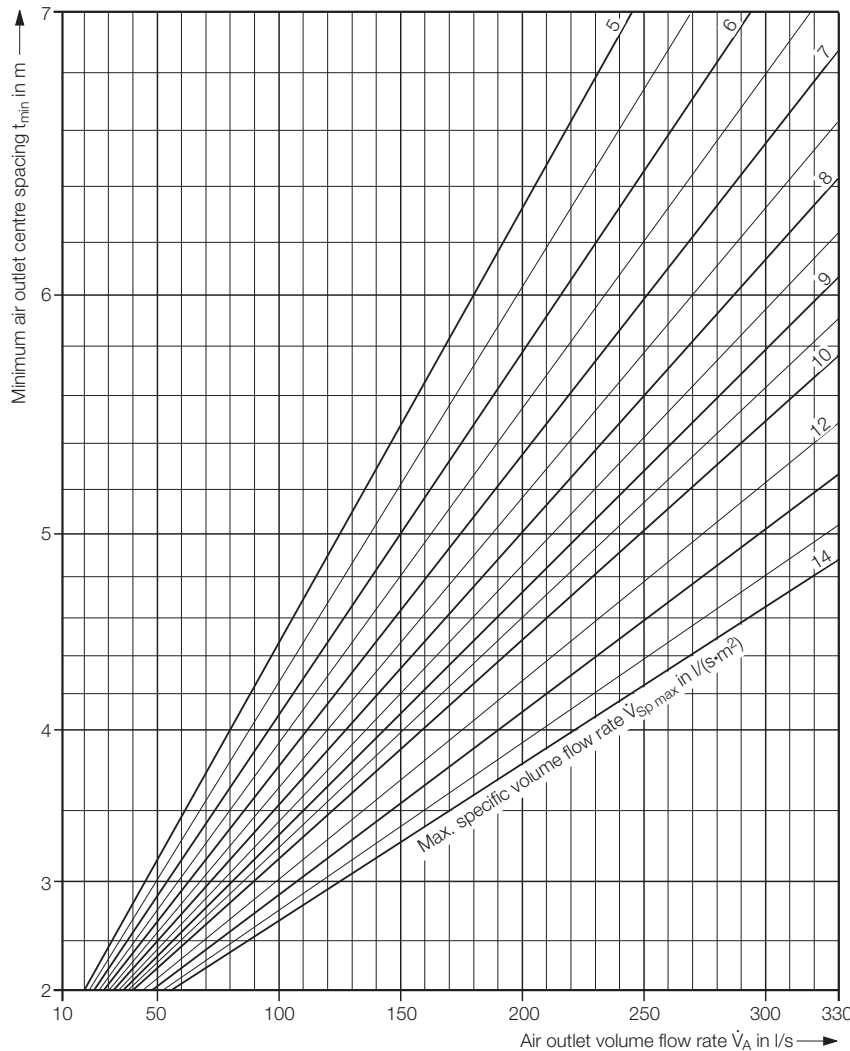

Key for layout:

- \dot{V}_A = volume flow rate per air outlet in l/s
- $\dot{V}_{A\ max}$ = max. volume flow rate per air outlet when cooling in l/s
- $\dot{V}_{A\ min}$ = min. volume flow rate per air outlet when cooling in l/s
- $\dot{V}_{Sp\ max}$ = max. specific volume flow rate per m² of floor area in l/(s·m²)
- $\dot{V}_{Sp\ act}$ = actual specific volume flow rate per m² of floor area in l/(s·m²)
- u = max. allowable indoor air velocity in m/s
- \dot{q} = max. specific cooling capacity in W/m²
- $\Delta\vartheta_{max}$ = max. temperature difference supply air to return air in K
- t_{min} = minimum air outlet centre spacing in m
- H = discharge height in m
- L_{WA} = sound power level in dB(A) ref. 10⁻¹² W
- Δp_t = total pressure drop in Pa

Graph 2: Minimum air outlet centre spacing

Microdrall

Sound power level, pressure drop and type code

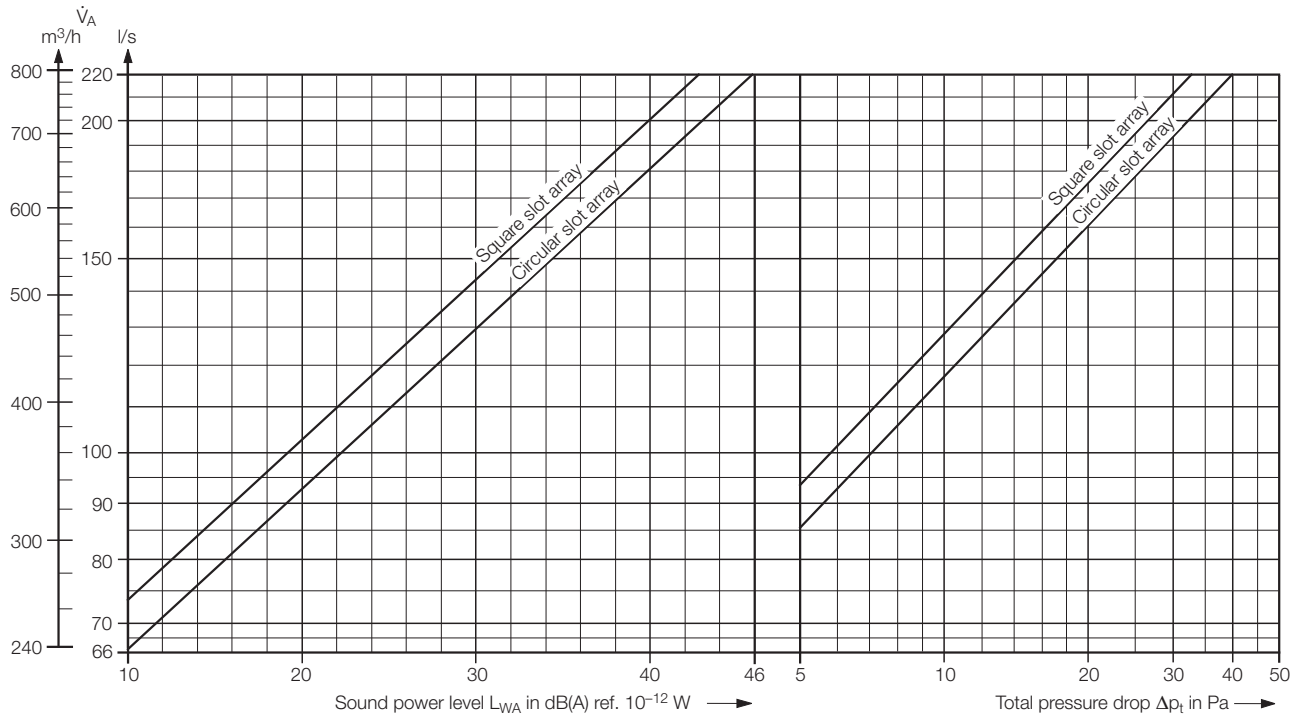

Graph 3: Sound power level and pressure drop

Type code

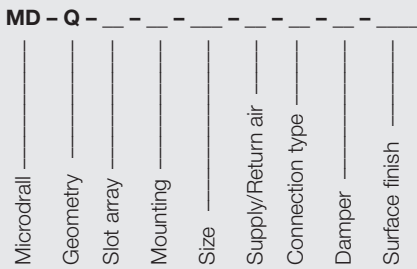

Geometry

Q = square face

Slot array

Q = square array
R = circular array

Mounting

D = flush with ceiling
F = freely suspended ¹⁾

Size

600 = size 600 (595 x 595 mm)
625 = size 625 (620 x 620 mm)

Supply/Return air

Z = supply air
A = return air

Connection type

O = no connection piece (only discharge element)
KO = connection box with no seal at the spigot
KD = connection box with seal at the spigot

Damper

O = no volume flow damper
R = with volume flow damper adjustable from room

Surface finish

9010 = face painted to RAL 9010, semi-matt
.... = face painted to RAL

¹⁾ On request

Microdrall

Tender text

Tender text – Supply air outlet

..... units

Microdrall to generate high-induction radial air jets for high-quality indoor air flow, with symmetric jet dispersion, installation flush with ceiling,

consisting of:

- air outlet element with square face and radial slots for air discharge – slots in square or circular array; with central fastening screw with cap
- connection box with central fastening device for the air outlet element, boreholes for suspension, lateral spigot optionally fitted with lip seal as well as with volume flow damper adjustable from the room.

Material:

- Air outlet element made of galvanized sheet metal with powder coating, face painted to RAL 9010, pure white ¹⁾
- Connection box made of galvanized sheet metal

Make: _____ Krantz Components
Type: MD – Q – _ _ _ _ _ – _ _ _ _ _ – _ _ _ _ _

¹⁾ Other colours on request

– Return air inlet

..... units

Microdrall for use as return air inlet, installation flush with ceiling,

consisting of:

- air outlet element with square face and radial slots for air intake – slots in square or circular array; with central fastening screw with cap
- connection box with central fastening device for the air outlet element, boreholes for suspension, lateral spigot optionally fitted with lip seal as well as with volume flow damper adjustable from the room.

Material:

- Air outlet element made of galvanized sheet metal with powder coating, face painted to RAL 9010, pure white ¹⁾
- Connection box made of galvanized sheet metal

Make: _____ Krantz Components
Type: MD – Q – _ _ _ _ _ – _ _ _ _ _ – _ _ _ _ _

Subject to technical alterations.

Krantz GmbH

Uersfeld 24, 52072 Aachen, Germany

Phone: +49 241 441-1

Fax: +49 241 441-555

info@krantz.de | www.krantz.de

The logo for Krantz GmbH, featuring the word "Krantz" in a stylized, blue, cursive script font.